

AG-6-CH4-28M2 LASER METHANE SENSOR

Mining series



Features

- ✓ *Accurate temperature control detection*
- ✓ *Water vapor resistant design*
- ✓ *Low power consumption design*
- ✓ *Real-time temperature compensation*
- ✓ *Explosion-proof design*

Description

AG-6-CH4-28M2 laser methane sensor is developed based on tunable laser gas absorption spectroscopy (TD-LAS). According to the absorption characteristics of methane gas molecules to 1653.7nm infrared "fingerprint spectrum", the concentration of methane gas is detected by direct absorption spectroscopy. The sensor adopts the folding optical path structure design, long absorption path, high detection sensitivity and accuracy, and resistance to water vapor and other gas interference; At the same time, the laser and photodetector devices with excellent low-temperature performance combined with the wide temperature compensation correction algorithm have strong environmental applicability. Standard thread mounting interface and standard communication protocol design, strong versatility; As the core component of methane gas detectors and monitors, it can be widely used for detecting methane gas leaks and triggering alarms in various environments, including underground spaces, the catering industry, the industrial chemical sector, and coal mines.

Mining series LASER METHANE SENS

Technical Specification

Measuring Range	0-100% VOL (CH ₄)	
Response Time(T90)	< 20s	
Measurement Error	< ±0.05VOL (0-1% VOL) < ±5% VOL (1-100% VOL)	
Stability of Displayed Value	≤ ±0.04%VOL (0 -1.00%VOL) ≤ ±0.40%VOL (10.0 -100%VOL)	
Operating Voltage	3.3V	
Operating Current(Average)	< 40mA	
Peak Current	< 100mA	
Output Type	3.3V TTL level UART	
Temperature Range	-10 - 50°C (Operating) -40 - 60°C (Storage)	
Humidity Range	0-98%RH (non-condensing)	
Pressure Range	80-120 kPa	
Weight	255g	
Expected Life	7 years	
Warranty	12 months	
Explosion Proof Signs	Ex ia IIC T6 Ga	
IP Rating	IP 66	
Intrinsic Safety	Ui:3.3V Pi:0.250W Li:3.14uH	Ii:50mA Ci:20uF

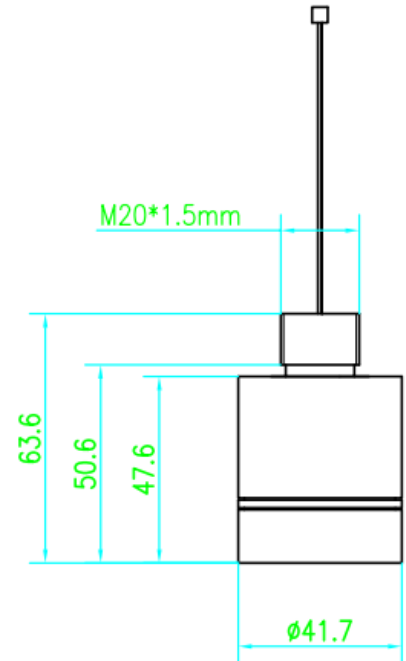

IMPORTANT NOTICE

The sensors contain precision optical components, please avoid severe impact. The operating voltage of the sensor is 3.3V. It is forbidden to supply more than 3.6VDC to the sensor in order to avoid damaging the sensor.

Under normal operating conditions, the sensor is warranted to be free of defects in material and workmanship for the specified period provided the sensor is properly installed and operated. The sole remedy for a sensor determined to be defective by Apollosense Ltd is limited to replacing the sensor. Apollosense Ltd will not be liable for the buyer's negligence, misapplication, abuse, or accident.