

EM5042A - Evaluation Module for TGS5042

Description:

The EM5042A evaluation module is designed to perform the testing and evaluation of the electrochemical carbon monoxide sensor TGS5042, which features high selectivity to CO, high repeatability and a long life. This module is useful for evaluating basic performances of TGS5042 gas sensor, and as a reference of application circuit.

Features:

- * Converts sensor output current to voltage output
- * Module designed with electrical noise reduction for stable operation
- * Anti-polarization circuit during power OFF period

Operation:

The TGS5042 CO sensor is placed into the sensor socket. EM5042A goes into normal operation within one minute after first being powered on. If CO gas is not present in ambient conditions, output voltage is 1.0V. If CO gas is present, the output current generated from the TGS5042 sensor^(*) is converted into output voltage. A linear relationship exists between output voltage and CO gas concentration. By measuring in advance the output voltage in a known CO gas concentrations, CO gas concentration can be calculated from the measured output voltage values^{(**)(***)}.

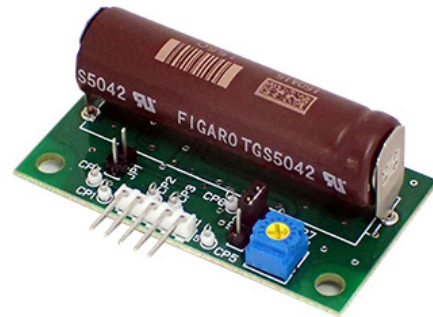

* Sensor not included

^{*1} For more details of characteristics and performance of TGS5042 sensor, refer to *Technical Information for TGS5042*.

^{*2} The main function of this module is to simply convert sensor output current into voltage output without temperature compensation. For more information on a temperature compensation circuit, refer to *Application*

Notes for TGS5xxx or contact Figaro.

^{*3} A calibration curve is available upon request if this module is ordered together with the sensor. The calibration curve represents the relationship between CO gas concentration and output voltage of the module with a particular sensor. The calibration curve is provided for reference purposes only.

Dimensions:

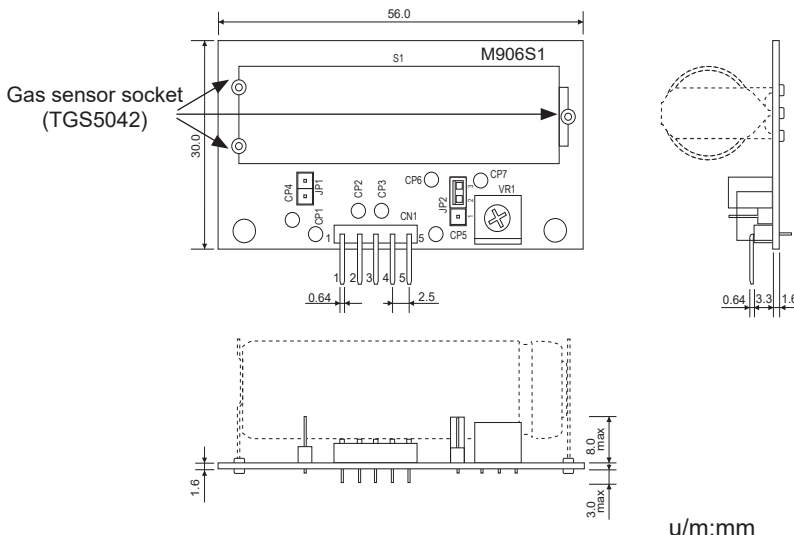

u/m:mm

- * The sensor is to be put in the sensor socket as shown in the above photo.
- ⚠ The pin tip of the sensor is sharp. Be careful to avoid injury when handling.
- * Suggested female connectors mating to the 5 pin connector (JST MB5P-90S):
JST XHP-5P or
JST 05JQ-BT

Schematic Diagram:

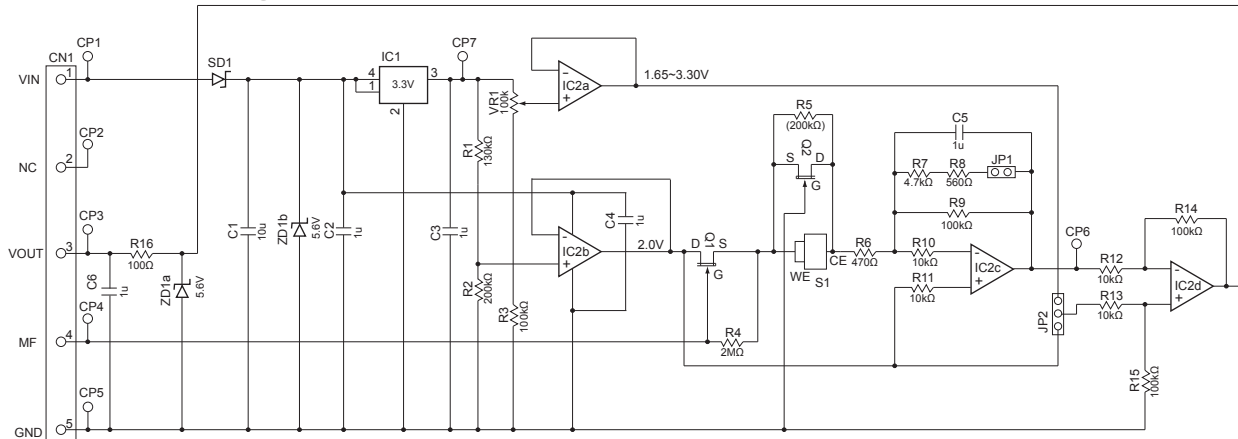

Pin Connections:

Pin No.	Name	Description
1	VIN	Input voltage 5.0±0.2V DC
2	NC	No connection
3	VOUT	Output voltage
4	MF	Self-diagnosis control input
5	GND	Ground

Sensor output current I_s (A) is calculated from output voltage V_{OUT} (V) between Pin #3 (V_{OUT}) and Pin #5 (GND) using the following formula:

$$I_s = (V_{OUT} - 1.0) / (1.0 \times 10^6)$$

Specifications:

Item	Specification
Product Name	Evaluation module for TGS5042
Model No.	EM5042A
Target gas	Carbon monoxide
Current consumption	<0.5mA
Output voltage (V_{OUT})	1.00±0.05V DC in zero air up to V_{IN} -0.5V max in CO gas
Output amplification factor	1.0×10^6
Operating conditions	0~60°C, <95%RH (no temp compensation)

NOTE1:

Maximum measurable concentration is about 1,500ppm when input supply voltage is 5V in std specifications. For higher concentrations, please contact Figaro Engineering Inc.

NOTE2:

Please contact Figaro Engineering Inc. for use of self-diagnosis control input Pin No. 4.

NOTE3:

Please do not touch or adjust VR1, JP1 and JP2. These items have been adjusted so that standard driving conditions are applied. If changed, the sensor may be damaged.

FIGARO ENGINEERING INC.
 1-5-11 Senba-nishi
 Mino, Osaka 562-8505 JAPAN
 Phone: (81)-727-28-2045
 URL: www.figaro.co.jp/en/