

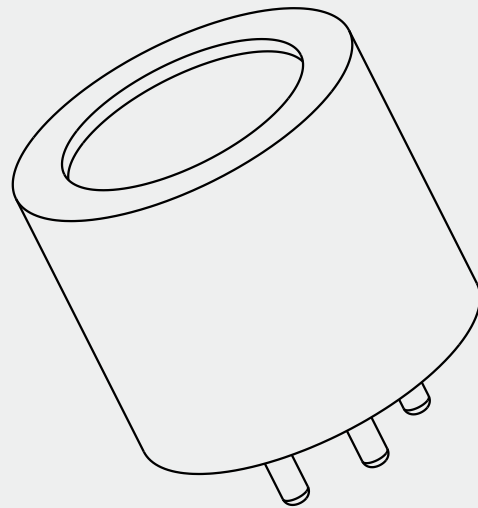

MPY20-HC-CH4

Infrared Gas Sensor



Product Datasheet

S P E C I F I C A T I O N

◆ Product overview



The gas sensor based on the infrared absorption principle has the following strengths: good stability, strong selectivity, no oxygen dependence, wide range of detection, long service life, long maintenance cycle, powerful anti-jamming capability, etc. It becomes the gas detection development trend and can rapidly replace gas sensor based on the traditional principle.

MPY20-HC-CH4 infrared gas sensor is designed with the latest technology, and achieves the constant working current of sensor when adopting low power processor and infrared source to control the overall power consumption, to guarantee the power circuit is free from the current shock influence and the sensor runs more stably.

MPY20-HC-CH4 sensor adopts the latest design algorithm, including the gas concentration algorithm, calibration algorithm, temperature compensation algorithm, humidity compensation algorithm, etc. The sensor adopts 32-bit core industrial-grade microprocessor, is rapid in arithmetic speed and wide in operating temperature range, coordinates the latest algorithm to guarantee the high efficiency, high accuracy, stability and reliability of sensor data operation, and is suitable for different work environment.

The minimum output value and maximum output value of analog voltage signal of MPY20-HC-CH4 sensor are 0V and 2.5V, respectively. Users can configure the zero output voltage value, full-range output voltage value, output voltage deviation value, output mode, etc. with PC configuration software so that they can rapidly and flexibly adjust in such demand. The configuration parameters are kept after power outage.

Digital communication baud rate of MPY20-HC-CH4 sensor can be set as 19200, 38400 or 115200 by users. The digital communication of sensor includes the active mode and passive mode. In active mode, sensor proactively and continuously sends the real-time measurement data as per the configured data transmission interval time (1-99S); In passive mode, the sensor sends the measurement data after waiting for the command about data reading at terminal in real time, and the configuration parameters are kept after power outage.

◆ Features

- Standard size
- Built-in temperature compensation and humidity compensation
- Digital signal output
- Linear analog signal output
- Small-scale integration
- Intrinsic safety design
- Low-power consumption design
75mA (maximum value: 80mA)
- Evaluation test board can monitor the data of 4 sensors at the same time by coordinating PC communication software.
- Explosion-proof design
- Deliver calibration
- Constant current design
- Fault diagnosis and fault code output
- Various digital signal communication modes are optional for users
- Digital communication baud rate can be configured by users
- Analog signal output range can be configured by users
- Evaluation test board can conduct rapid zero calibration and alignment and configure each parameter of sensor by coordinating PC configuration software.

◆ Application scene

- Petrochemical engineering
- Methane concentration measurement
- Leakage of fuel gas and gasoline
- Mine environmental monitoring
- Municipal pipe
- Industrial healthcare

Contents

MPY20-HC-CH4 Sensor characteristics	2
Application	2
Overview	2
Technical Data	4
Definition of external pin	5
Hardware description	5
Application description	6
Communication	6
Universal Asynchronous Receiver Transmitter (UART)	6
Serial communication setting	6
Digital output	7
Analog output	7
Zero calibration	8
Sensitivity (SPAN) calibration	8
Error code	9
Typical pressure test data	9
Precautions	10
Version history	10

◆ Technical indicators

Table I Technical Parameters I

	Minimum	Typical	Maximum
Power supply			
Input voltage	3.2VDC	3.3VDC	5.5VDC
Input current	70mA	75mA	80mA
Input current fluctuation	/	±2%	±5%
Temperature			
Working temperature	-40°C	+20°C	+70°C
Storage temperature	-40°C	+20°C	+85°C
Humidity			
Working humidity	0	/	95%, non-condensing
Storage humidity	0	/	95%, non-condensing
Pressure			
Operating pressure	80kPa	/	120kPa
Storage pressure	80kPa	/	120kPa
Size			
Diameter	19.8mm	20.0mm	20.2mm
Storage pressure	15.8mm	16.0mm	16.2mm
Pin height	4.0mm	5.0mm	6mm
Weight	/	< 15g	/
Shell material	/	Stainless steel	/
lifetime	/	>5 years	/

The sensor's working voltage is recommended as 3.3V (minimum: 3.2V, and maximum: 5.0V). Over 5.5V may damage the sensor. For the gas sensor based on infrared absorption principle, the gas concentration measurement is related to the gas molecule density, and the molecule density is directly related to air pressure. Therefore, the air pressure would influence the sensor's data measurement. When the range of atmospheric pressure for sensor to apply to environment is wider, users are suggested to add pressure sensor and compensation software. The typical pressure test data chart would be offered in the subsequent chapters for reference.

Table II Technical Parameters II

	Minimum	Typical	Maximum
Analog output			
Output voltage	0.0VDC	/	2.5VDC
Output current	/	/	5mA
Digital output (TTL - 3.0V)			
Low level	/	/	0.4V
High level	2.4V	/	/
Digital input (TTL - 30V)			
Low level	-0.3V	/	0.8V
High level	0.7*3V	/	3.3V
Serial communication baud rate			
Baud rate	19200	38400	115200

MPY20-HC-CH4 Infrared Gas Sensor

Sensor is at the initialization and power-on preheating process 60S before power-on, wouldn't respond to external serial command, and may output the initialization data. Users shall neglect the output data 60S before power-on of sensor.

Table III Technical Parameters III

Warm up time	60S
Response time	T90≤25S (ambient temperature: 20°C)
Resolution ratio	0~10%: 0.01% 10~100%: 0.1%
Zero repeatability	±2%FSD (ambient temperature: 20°C)
Sensitivity repeatability	±2%FSD (ambient temperature: 20°C)
Long-term zero drift	±1%FSD/ (ambient temperature: 20°C)
Precision	0~1% VOL: ±0.06% VOL 1~100%VOL: Truth value: ±6%

◆ Definition of external pin of sensor

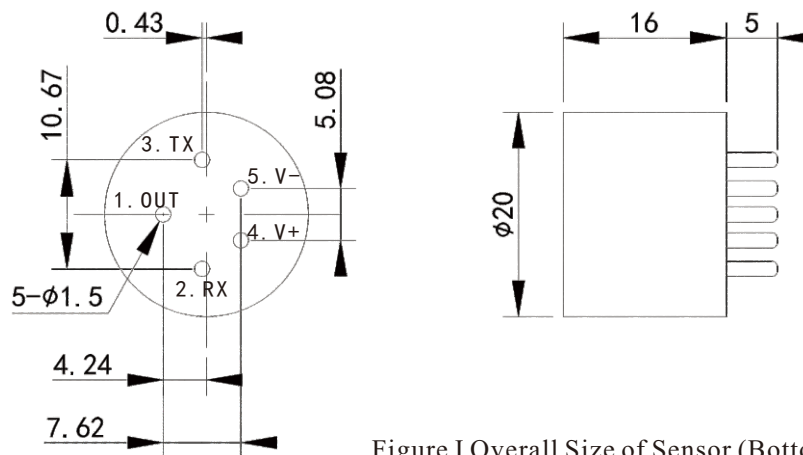

Figure I Overall Size of Sensor (Bottom View)

Pin No.	Name	Description
1	OUT	With analog output, it synchronizes with digital output and terminal can connect ADC or voltmeter.
2	RXD	Sensor UART communication receiving end connects the user terminal TXD.
3	TXD	Sensor UART communication sending end connects the user terminal RXD.
4	V+	The voltage of sensor's positive pole shall be 3.3 - 5.0V.
5	V-	The sensor's negative pole simulates output and data communication common land.

◆ Hardware design description

To ensure the normal and stable operation of sensor, the following several aspects shall be noted for the corresponding hardware design of sensor.

1. The hardware is suggested to design the voltage limit circuit (V+, RXD and TXD), and the TVS (transient voltage suppressor diode) with protection voltage of about 5.0V is recommended and selected for surge voltage limit.
2. The hardware is suggested to design the limited current circuit. The self-recovery insurance device is recommended with the current limit value between 150mA-250mA, and the backend of self-recovery insurance device shall be equipped with the filter capacitor.
3. It is suggested that the sensor is powered by independent IC, the output voltage is 3.3V, and the output current is no less than 150mA. LDO (low dropout regulator) owns smaller ripple voltage, therefore it is preferred.
4. It is strictly forbidden to weld and cut off the external pin of sensor.

MPY20-HC-CH4 Infrared Gas Sensor

Figure II is the Circuit Diagram of Typical Application of Sensor. Since the sensor's serial communication is TTL electric level, the MCU in figure directly connects the sensor's serial interface (TXD and RXD) to read the sensor data in real time. If the standard RS232 electric level of PC is used for communication with sensor, it is necessary to add TTL- RS232 conversion circuit. Our company's evaluation circuit board matches with our company's PC testing software for comprehensive testing of sensor. In the meanwhile, the evaluation circuit board also contains a Liquid Crystal Display to display main measurement data of sensor in real time.

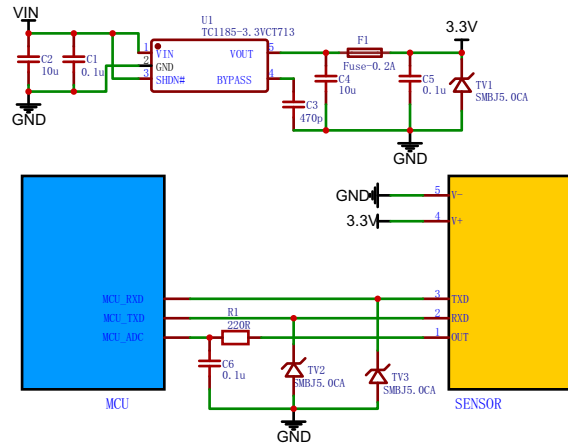

Figure II Circuit Diagram of Typical Application of Sensor

◆ Application description

Communication

Sensor communication in two kinds of methods

1. The Analog to Digital Converter (ADC) is used to read the sensor's analog voltage output. The analog voltage value output by sensor and the measured gas concentration value show the linear relation. Please refer to the details in "analog output" chapter. Such kind of communication method is relatively simple in use, but only can read the one-way analog voltage value, rather than send the command to sensor (that is, the operate of sending data to sensor, such as zero calibration, alignment, etc. can't be completed). Since the gas concentration is obtained by converting analog voltage value, the gas concentration value of terminal will generate extra error. Such error value is mainly composed of the internal DAC precision of sensor, terminal ADC precision and differential pressure value of public ground wire.
2. The digital interface of Universal Asynchronous Receiver Transmitter (UART) is used for data sending and receiving with sensor. The output data of digital interface contain many measurement data such as gas concentration, temperature, humidity, etc. Those data are conducive to users knowing more about the working environment and sensor's working status, and rapidly conducting zero calibration, alignment, etc. of sensor. The second kind of method is suggested.

Universal Asynchronous Receiver Transmitter (UART)

Universal Asynchronous Receiver Transmitter (UART) is a kind of protocol about mutual communication among equipment, and is very applicable to the protocol for mutual communication among MCU or between MCU and PC. MPY20-HC-CH4 sensor shall be subject to the Universal Asynchronous Serial Communication Protocol which is suitable for any application of sensor due to its strong universality. Refer to the subsequent paragraphs for the format setting of digital signal transmission with MPY20-HC-CH4 through UART and more details.

Regardless of communication with another MCU or PC through serial communication protocol, two equipment must have two same setups, otherwise, the communication may go wrong or be unstable.

Serial communication setting

The recommended setup in Table VI is suggested for the communication with UART of MPY20-HC-CH4 sensor. Please confirm whether your communication setup is the same as the sensor when trying to conduct communication with sensor or failing to conduct communication.

Descriptions: Since users can configure the MPY20-HC-CH4 sensor Baud rate, the defaulted Baud rate is 38400. If users change the Baud rate, the Baud rate shall be configured as per actual condition upon use.

Table IV UART Parameter Table

S/N	Parameter name	Parameter value
1	Baud rate	38400
2	Data Bits length	8
3	Parity bit	None
4	Stop bits	1
5	Handshaking signal	None

MPY20-HC-CH4

Infrared Gas Sensor

Digital output

The data digital measured by the MPY20-HC-CH4 sensor in real time is divided into two methods: "passive mode" and "active mode".

When the sensor outputs data in "passive mode", wait for the terminal sending out the command about one-time data reading and then return to conduct real-time data measurement one time. When the sensor outputs data in "active mode", send out the command about real-time data measurement as per the data output cycle configured by users in advance, without waiting for terminal sending out command about data reading.

When the sensor is at the "passive mode" or "active mode", there are two kinds of data with hexadecimal output: "simple data" and "all data". Refer to Table V for data list. Besides, the "active mode" also provides the "simple data" ASCII output. There are 11 data in the output table of "all data", and the "simple data" only output the corresponding data of S/N 2-5 in the table. Refer to "MPY20 series infrared gas sensor user communication protocol" for details.

Table V Measurement Data List

S/N	Variable type	Variable name	Default value	Description
1	uint32_t	StatusFlags	0	Sensor working status
2	float	Concentration	0	Gas concentration
3	float	Temperature	0	Temperature
4	float	Humidity	0	Humidity
5	float	Fa	0	Absorptivity
6	uint16_t	MainVpp	0	Main channel value
7	uint16_t	RefVpp	0	Reference channel value
8	uint16_t	MainMin	0	Minimum value of main channel
9	uint16_t	MainMax	0	Maximum value of main channel
10	uint16_t	RefMin	0	Minimum value of reference channel
11	uint16_t	RefMax	0	Maximum value of reference channel

Analog output

The range of analog output voltage value of MPY20-HC-CH4 sensor is 0-2.5VDC, the output voltage value and measurement concentration value show the linear relation, and the maximum output current is 5mA. Please do not surpass its maximum output current in use, otherwise, the sensor may have abnormal operation. There are 5 parameters in MPY20-HC-CH4 sensor analog output for flexible configuration by users as per specific condition: "analog output mode (DacConfig)", "analog output offset (DacOffset)", "analog output zero output value (DacZero)", "analog output full-range output value (DacFsd)" and "analog output range (DacOutRange)". Such 5 configuration parameters can meet the demands of most application scenes.

DacConfig can be configured as segment I mode and segment II mode, with the specific mode description as below:

Segment I mode: The analog output voltage value and measurement concentration value show the segment I linear relation, and the range of analog output voltage is determined by DacZero and DacFsd.

If DacZero = 0.4V, DacFsd = 2.0V, analog output range is 5%VOL, and the measurement concentration value is 0.5%VOL, the analog output voltage is: $U=(0.5/5)*(2.0-0.4)+0.4=0.16+0.4=0.56V$

If DacZero = 0.4V, DacFsd = 2.0V, analog output range is 100%VOL, and the measurement concentration value is 0.5%VOL, the corresponding output voltage is: $U=(0.5/100)*(2.0-0.4)+0.4=0.008+0.4=0.408V$

Segment II mode: Analog output voltage value and measurement concentration value show the segment II linear relation (only limited to the analog output range of 50% and 100%VOL). The analog output voltage segment II range is determined by DacZero and DacFsd, the voltage interval among segment 2 is 0.2V. The low-section analog output voltage range has linear representation of gas measurement range as specified in LowConRange (0-5%), while the high-section analog output voltage range has linear representation of gas measurement range as specified in HighConRange (5-50% or 5-100%).

If DacZero=0.4V and DacFsd=2.0V, low-section analog output voltage range is 0.4~1.1V and high-section analog output voltage range is 1.3~2.0V. The spacing between high section and low section is 1.3-1.1~0.2V, and both sections' range is 0.7V.

DacOffset is the offset of analog output voltage value, with the unit of V, that is, when sensor converts the output analog voltage value as per concentration, which is the final output value after superposition of DacOffset. It shall be noted that the setting value of DacOffset, plus DacZero, shall not be less than 0.0V, and the setting value of DacOffset, plus DacFsd, shall not be more than 2.5V.

The DacZero is analog output zero value, that is, when sensor measures the gas concentration as 0, the

MPY20-HC-CH4

Infrared Gas Sensor

corresponding analog voltage output value's setting range is $0.0V \leq \text{DacZero} \leq 2.0V$ and meets $(\text{DacZero} + \text{DacOffset}) \geq 0.0V$.

The DacFsd is the analog output full-range value, that is, when sensor measures gas concentration as full-range value, the corresponding analog voltage output value's setting range is $0.4V \leq \text{DacFsd} \leq 2.5V$ and meets the $(\text{DacFsd} + \text{DacOffset}) \leq 2.5$ and $\text{DacFsd} \geq \text{DacZero}$ at the same time.

DacOutRange is the analog output range and can be configured as 0.1,0.2,0.5,1,2,5,10,20,50,100%VOL. The analog output range can't surpass the digital output range. The analog output-related parameters, after smooth configuration, immediately come into effect.

Since the power-on output value of sensor and the fault output value of analog output are less than or equal to 0.2V, the users are suggested to configure the sensor analog output $(\text{DacZero} + \text{DacOffset}) > 0.2V$. Refer to Table VI for the delivery default value of 5 parameters.

Table VI Analog Output Parameter Table

S/N	Parameter symbol	Parameter name	Default value
1	DacConfig	Analog output mode	Section 1
2	DacOffset	Analog output	/
3	DacZero	Analog output	4.0(V)
4	DacFsd	Analog output	2.0(V)
5	DacOutRange	Analog output	0-5%

When sensor's analog output parameter $(\text{DacZero} + \text{DacOffset}) > 0.2V$, refer to Table VII for the relevant description of typical value of sensor analog output.

Table VI Typical Value of Analog Output

S/N	Analog output value	Condition
1	0.2V	60S before sensor power-on
2	0.1V	Sensor's analog output parameter error or fault
3	0V	Sensor analog output fault
4	DacZero+DacOffset	Detected gas concentration value is zero
5	DacFsd+DacOffset	Detected gas concentration value is full-range value or surpasses the value of range
6	>2.55V	Sensor analog output fault

Zero calibration

After sending the zero calibration command (refer to "MPY20 series infrared gas sensor user communication protocol" for command details), the sensor keeps the data about 10S before receiving the zero calibration command as per the environment data, etc. as zero data in power-off memory. After sensor finishes the zero calibration, return to execution result command within 2S in general. To guarantee the accuracy and reliability of zero calibration, the terminal shall send out the zero calibration command to sensor after data are completely stable for 30S at least.

*Prompts: It is suggested that the sensor shall have power-on preheating for over 2 hours before zero calibration, and there is no target detection gas in environment, otherwise, the zero calibration may fail or the measurement is inaccurate after calibration.

After sending out zero calibration command, terminal shall wait for the command about sensor return. Due to the wrong operation or sensor problem, etc., the returned command may not be ACK data package. In case of the NAK data package, it is necessary to check the false code in NAK data package to eliminate the potential problem.

Sensitivity (SPAN) calibration

After sending the sensitivity (SPAN) calibration command (refer to "MPY20 series infrared gas sensor user communication protocol" for command details), the sensor keeps the data about 10S before receiving the sensitivity (SPAN) calibration command as per the environment data, etc. as sensitivity (SPAN) data in power-off memory. After sensor finishes the sensitivity (SPAN) calibration, return to execution result command within 2S in

MPY20-HC-CH4

Infrared Gas Sensor

general. To guarantee the accuracy and reliability of sensitivity (SPAN) calibration, the terminal shall send out the sensitivity (SPAN) calibration command to sensor 30S after the data are completely stable at least.

*Prompts: It is suggested that, before the sensitivity (SPAN) calibration, the sensor shall have power-on preheating for over 2 hours at first, and the used calibration gas concentration value is the same as the concentration data in calibration command sent, otherwise, the calibration fails or the measurement value is inaccurate after calibration.

After sending out calibration command, terminal shall wait for the command about sensor return. Due to the wrong operation or sensor problem, etc., the returned command may not be ACK data package. In case of the NAK data package, it is necessary to check the false code in NAK data package to eliminate the potential problem.

The shorter the interval between "zero calibration" and "sensitivity (SPAN) calibration" is, the better the condition is. Execute "zero calibration" at first and then execute "sensitivity (SPAN) calibration" to avoid single execution of one of them.

The shorter the interval between "zero calibration" and "sensitivity (SPAN) calibration" is, the smaller the environment error (such as temperature, humidity, pressure, etc.) between them is. The smaller extra data error brought by environment can effectively improve the sensor's detection accuracy. For the gas concentration value of "sensitivity (SPAN) calibration", it is suggested to adopt the standard gas with 50% full range. If the sensor range is 0-5%VOL, it is suggested to use the 2.5%VOL standard gas. In case of no standard gas with suggested value, the standard gas close to the suggested value shall be selected as far as possible.

Error code

When sensor returns to the NAK data package, the last byte in three bytes is the false code. As per the returned error code, the users can find the problem. Refer to Table VIII for the relevant descriptions about error code.

Table VII Error Code

S/N	Error code (decimalism)	Error description
1	01	Variable unreadable
2	02	Variable non-writable
3	03	Beyond the operation scope
4	04	False data length
5	05	Undefined command or bytes
6	06	Verification failure
7	07	Wrong edition
8	08	Sensor is busy
9	16	Zero value is beyond normal scope
10	18/22	Calibration value at low concentration range is excessive in deviation
11	24/26/28	Input calibration gas concentration value surpasses the normal range

◆ Typical pressure test data

Table IX Test Data of Pressure - Gas Measurement Value

Test condition

Standard gas: 60%VOL methane gas;
Pressure range: 80-120kPa.

Test sequence

Take 10kPa as step value,
Pressure value is from big to small
Test data are shown in Table IX.

S/N	Pressure value (kPa)	Gas measurement value (VOL%)	After normalization of gas measurement value
1	120	77.88	13337
2	110	67.51	11562
3	100	58.39	1
4	90	48.50	0.8306
5	80	39.88	0.6829

The corresponding gas measurement value 58.39%VOL with the pressure value as 100kPa standard atmospheric pressure is taken as the base value for the normalization processing of gas measurement value. The linear fitting is conducted for the gas measurement value data and air pressure value after normalization processing. Refer to Figure III for fitting graphics.

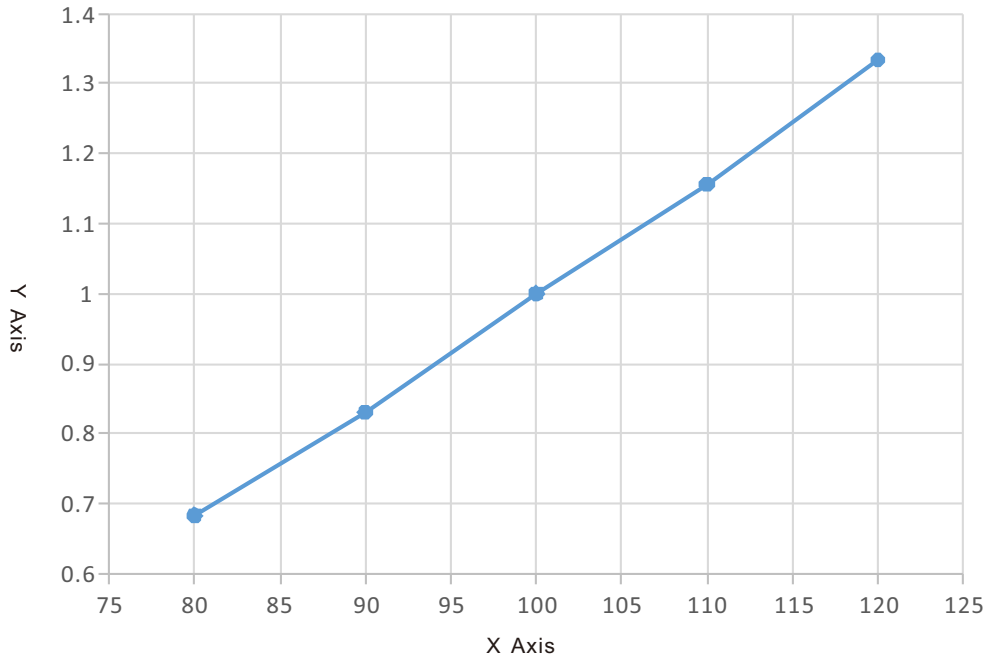

Figure III Relation Drawing of Air Pressure - Gas Measurement Value

Fitting formula is: $Y=A+B*X$

wherein, $A=-0.6073$, $B=0.01611$, Y =gas measurement value and X = air pressure value. So the slope of fitting straight line $B=0.01611$. In actual application, the fixed value slope B and air pressure's real-time measurement value X can be used for pressure compensation of gas measurement value. One of the following compensation method is only for reference.

$$Y_{comp}=Y/[1+B*(X-100)]$$

Wherein:

Y_{comp} is the gas measurement value after pressure compensation;

Y is the real-time output gas measurement value of sensor;

B is the fixed value slope 0.01611;

X is the real-time measurement value of air pressure.

For example, when the air pressure's real-time measurement value $X=120$ kPa, the real-time output gas measurement value of sensor $Y=77.88$ VOL% because the air pressure in work is higher than the standard air pressure. At this time, the actual gas measurement value Y_{comp} at the workplace of sensor is:

$$\begin{aligned} Y_{comp} &= Y/[1+B*(X-100)] \\ &= 77.88/[1+0.01611*(120-100)] \\ &= 58.90(\text{VOL}\%) \end{aligned}$$

For example, when the air pressure's real-time measurement value $X=80$ kPa, the real-time output gas measurement value of sensor $Y=39.88$ VOL% because the air pressure in work is lower than the standard air pressure. At this time, the actual gas measurement value Y_{comp} at the workplace of sensor is:

$$\begin{aligned} Y_{comp} &= Y/[1+B*(X-100)] \\ &= 39.88/[1+0.01611*(80-100)] \\ &= 58.84(\text{VOL}\%) \end{aligned}$$

This shows that, due to the particularity of working environment, even if the workplace pressure is different from standard pressure, the gas measurement value can reach the normal measurement level through simple linear pressure compensation.

◆ Precautions

1. Sensor contacts the rubber materials. The rubber materials contacting sensor shall not adopt the materials containing cyanogen and nitrile, such as the isocyanate material which may result in the test failure of sensor even damage sensor.
2. Water is banned in sensor. There is an optical channel in sensor, the liquid would pollute the optical channel after entering and reduce the sensor performance even damage the sensor. In use, the waterproof breathable membrane (configured upon delivery) shall be pasted at the air inlet of sensor.
3. The use in corrosive gas environment is prohibited. The corrosive gas wouldn't influence the gas of sensor detection objective. But long-term operation of sensor in environment containing corrosive gas would slowly corrode the optical channel of sensor, further influencing the sensor performance even damaging the sensor.
4. Calibration operation problem In some scenes, the sensor shall be calibrated with air vent cap. Since the sensor's measurement data are influenced by pressure, the air vent cap must be equipped with inlet and outlet to guarantee the stable airflow and balanced air pressure.

◆ Version history

Date	Version	Change
2020.12.9	1.00	Initial version