

Photoionization Detector (PID) Sensors

7-Series

Senovol PID sensors are designed for the detection of a wide variety of volatile organic compounds (VOCs). In general, any compound with ionization energy (IE) lower than that of the lamp photons can be measured. Based on its proprietary ultraviolet (UV) lamp technology, Senovol PID sensors have the advanced features of high UV outputs, and long lamp life spans.

Product Dimensions

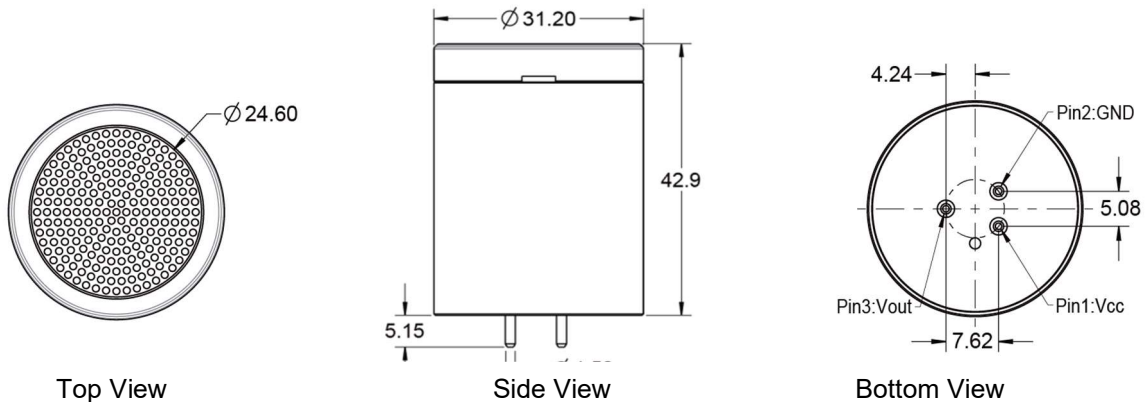

All dimensions in mm

Performance

Photon energy	10.6 eV
Measurement range	0 ~ 10000 ppm
Resolution	1 ~ 1000 ppb
Response time (T90)	< 5 seconds
Baseline shift (20°C)	70 ± 30mV
Linearity	linear from 0.05 ~ 3.0 V

Electrical

Supply voltage	3.3 ~ 5.5 V
Working current	< 180 mA at 3.3 V
Output signal	0.05 ~ 3.3 V

Mechanical

Enclosure	Stainless steel
Weight	80 grams

Environmental

Temperature range	-20°C ~ +50°C
Pressure range	1 atm ± 10%
Humidity range	0% ~ 99%RH Non-condensing

Lifetime

Storage temperature	0 °C ~ 30 °C
Operating lifetime	5 years (excluding lamp and electrodes)
Typical lamp life	20,000 hours
Storage life	2 years in original packaging
Warranty	24 months

Approvals

CE
Pending Intrinsic safety certification

Installation

Output signals from the sensor pins are different. Inappropriate use of the pins in product design will affect the sensor functionality. Exposure to high concentrations of solvent vapors should be avoided under any condition. Mechanical overstress may cause deformation of the sensor enclosure and damage the internal components including the lamp. If the sensor is used in extreme environmental conditions, please contact us for more details

Pin Out Details Pin 1 – VCC Pin 2 – GND Pin 3 – VOUT

Product Selection

Product Name	Part Number	Measurement Range	Photon Energy	Resolution	Sensitivity	Response Time
7PID-5	PID-106K-0050	0 ~ 5 ppm	10.6 eV	0.5 ppb	> 200 mV/ppm	< 5 s
7PID-10	PID-106K-0100	0 ~ 10 ppm	10.6 eV	1 ppb	> 100 mV/ppm	< 5 s
7PID-20	PID-106K-0200	0 ~ 20 ppm	10.6 eV	1 ppb	> 60 mV/ppm	< 5 s
7PID-100	PID-106K-1000	0 ~ 100 ppm	10.6 eV	10 ppb	> 10 mV/ppm	< 5 s
7PID-200	PID-106K-2000	0 ~ 200 ppm	10.6 eV	20 ppb	> 5 mV/ppm	< 5 s
7PID-1000	PID-106K-1001	0 ~ 2,000 ppm	10.6 eV	100 ppb	> 1 mV/ppm	< 5 s
7PID-5000	PID-106K-5001	0 ~ 5,000 ppm	10.6 eV	500 ppb	> 0.5 mV/ppm	< 5 s
7PID-10000	PID-106K-1002	0 ~ 10,000 ppm	10.6 eV	1,000 ppb	> 0.1 mV/ppm	< 5 s

Note

The performance data in this document is taken by applying isobutylene to the PID sensor using Senovol lab testers. The PID sensor may perform differently if gases other than isobutylene are used.

Sensitivity Temperature Data

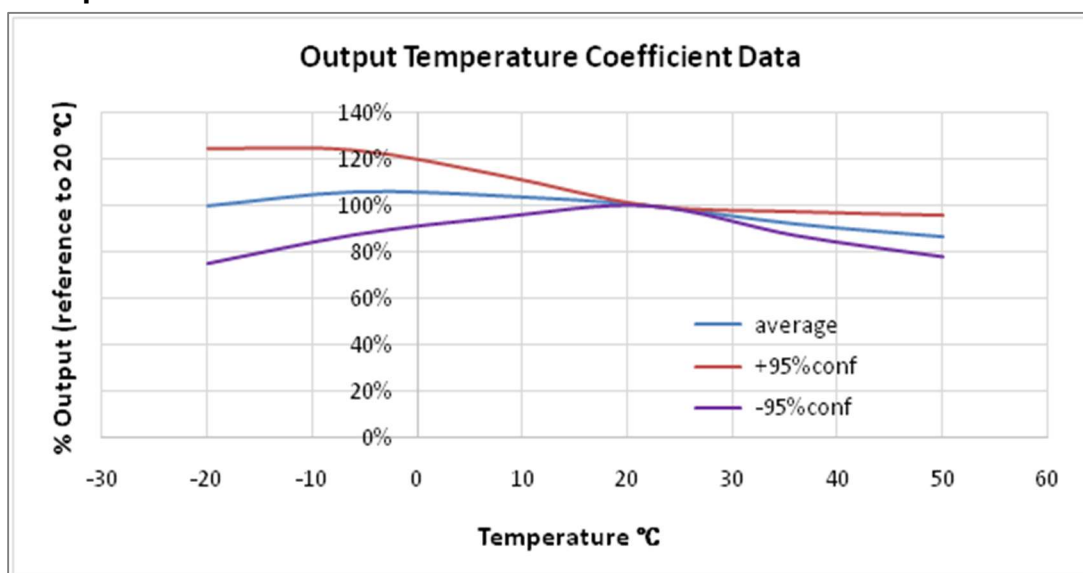

Safety Note

If the sensor is used in certain instruments for life critical applications, it is required to read the instrument user's guide carefully and comply with the calibration procedures by using the certified target calibration gas before each use. Failure to do so may cause serious injury and/or fatality. It is highly recommended for customers to validate the sensor performance using this document as a reference for their product designs or applications.